

DEFENDER[®] 5000 Washdown Bench Scales

Application Modes



Weighing: Determine the weight of items in the selected unit of measure.



Parts Counting: Count samples of uniform weight. Advanced auto-optimization software recalculates the average piece of weight as the overall weight increases.



Checkweighing/Counting: Compare the weight/count of a sample against target limits. Connect with Discrete I/O and Light Tower Kit for external check lights.



Percent Weighing: Measure the weight of a sample displayed as a percentage of a pre-established reference weight.



Dynamic Weighing and Display Hold: Weigh an unstable load. Scale takes an average of weights over a period of time. The Display Hold feature manually or automatically holds the last stable weight on the display.



Filling: Fill a container to a target weight. Progress bar displays filling status. Connect with Discrete I/O option kit for auto-filling system.

Other Standard Features and Equipment

User-configurable resolution up to 25,000d for general applications and up to 6,250e for legal-for-trade applications (depending on model and unit of measure), 150% overload capacity protection, checkweighing symbols with selectable operation and audible signal settings, menu lock switch, multiple selectable operating languages, selectable environmental and auto-print settings, stability indicator, overload/underload indicators, selectable adjust contrast settings, auto-dim display, auto-off, auto tare, non-slip adjustable rubber feet, a Wheel Kit option is also available for scales up to 300 kg.

Compliance

- **Metrology:** Measurement Canada (Indicators: NoA AM-6093, Platforms: NoA AM-6107); NTEP (Indicators: CC 18-065, Platforms: CC 18-077) Class III
- **Product Safety:** CAN/CSA C22.2 61010-1; UL61010-1; IEC/EN 61010-1
- **Electromagnetic Compatibility:** FCC Part 15 Class B; Canada ICES-003 Class B; IEC/EN 61326-1 Class B, basic environments
- **Compliance Marks:** CE; CSA

Accessories

Battery Kit, Li-ion, TD52	30424405	M16 Gland with Ferrite, to TD52	30379716
USB Host for Dongle, TD52	30424406	Micro SD Card, 8G	30303533
Light Tower, 3 Colors, 243mm, IP65 (Requires 30097591)	30424021	Analog Output Kit, TD52 ¹	30424403
In-use Cover Kit, TD52P	30424022	Second RS232/RS485/USB Kit, TD52 ¹	30424404
In-use Cover Kit, TD52XW	30424023	USB Host for Flash Drive ²	30572923
In-use Cover set (10), TD52P	30469948	I/O with Relay (2 In/4 Out) ³	30097591
In-use Cover set (10), TD52XW	30469949	WiFi/BT Dongle, OHAUS ² (Requires 30424406)	30412537
Printer Holder Kit, D52	30424025	Ethernet Kit, D52 ²	30429666
Wall Mount Kit, SST, TD52XW	30424026	Wheel Kit, Defender Series ¹ (For bases up to 300 kg)	30372146
Wall Mount Kit, CS, TD52P	30424027	Wheel Kit, SST, Defender Series ¹	30616409
LC Extension Cable, 9 meters, D52 ¹	30424409	Impact Printer SF40A	30064203
		Thermal Printer STP-103	80251992

¹ Cannot be used for legal-for-trade applications ² Only one of them can be used at the same time ³ Only one of them can be used at the same time

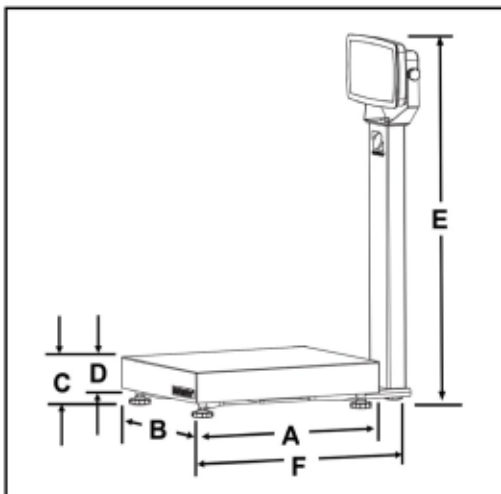

80775490_B 20210426 © Copyright OHAUS Corporation

OHAUS CORPORATION
7 Campus Drive
Suite 310
Parsippany, NJ 07054 USA

Tel: 800.672.7722
973.377.9000
Fax: 973.944.7177

www.ohaus.com

The management system governing the manufacture of this product is ISO 9001:2015 certified.

