

Valor™ 1000 Compact Precision Scales

Specifications

Single Display Model	V11P3	V11P6	V11P15	V11P30
Dual Display Model	V11P3T	V11P6T	V11P15T	V11P30T
Capacity x Readability	6.6 lb x 0.001 lb 105 oz x 0.02 oz 3 kg x 0.0005 kg 3000 g x 0.5 g	13 lb x 0.002 lb 210 oz x 0.05 oz 6 kg x 0.001 kg 6000 g x 1 g	33 lb x 0.005 lb 520 oz x 0.1 oz 15k g x 0.002 kg 15000 g x 2 g	66 lb x 0.01 lb 1058 oz x 0.2 oz 30 kg x 0.005 kg 30000 g x 5 g
Weigh Units	kilograms, pounds, grams, ounces			
Modes	Weigh, accumulate, checkweigh			
Keyboard	Four mechanical switches (right)			
Calibration	Digital external span calibration			
Display Type	0.8 in. / 20 mm H, 6-digit 7-segment LCD with blue LED backlight T models have dual displays (front and back of scale), non T models have single display on front of scale			
Display Indicators	Center of zero, stability, net, sum, over/accept/under check, weighing unit and battery charge status			
Tare Range	To capacity by subtraction			
Stabilization Time	<=3 seconds			
Auto Zero Tracking	User selectable from 0.1d to 2d			
Operating Temp / Humidity	32°F to 104°F (0°C to 40°C) at 10% to 95% relative humidity Non-condensing, up to 2.5 miles / 4000m above sea level			
Power	120 VAC / 9 VDC 500 mA AC adapter (included) Internal rechargeable sealed lead acid battery (included)			
Typical battery Life	80/100 hours (with / without backlight on) with 12-hour recharge time			
Construction	ABS plastic housing, stainless steel pan			
Safe Overload	120% of capacity			
Scale Dimensions	10w x 12d x 4.3h in / 250w x 307d x 110h mm			
Pan Size	9.9w x 7.1d in / 250w x 180d mm			
Carton Dimensions	12.75w x 6.25d x 11.9h in / 340w x 160d x 300h mm			
Net Weight	7 lb / 3.2 kg			
Shipping Weight	8.8 lb / 4.0 kg			

Outline Dimensions

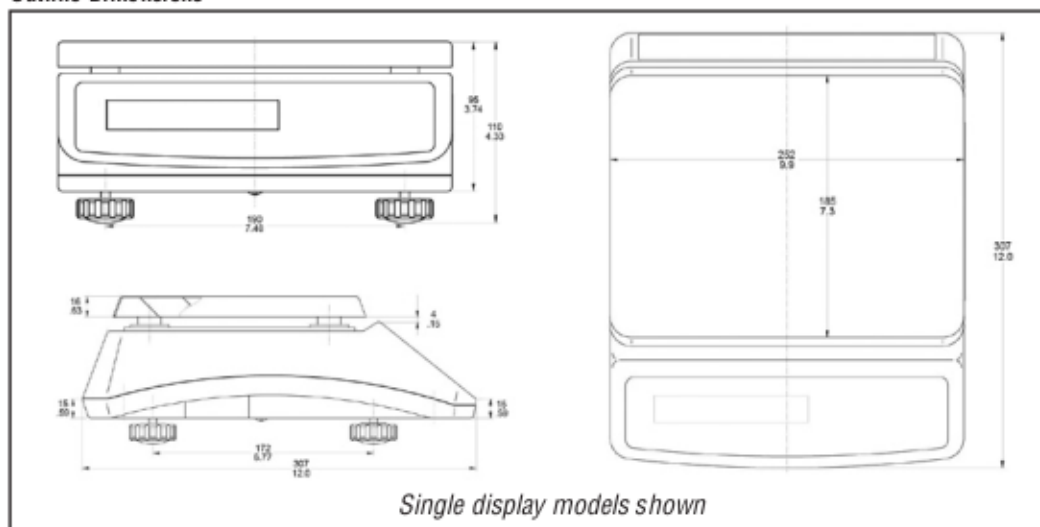

Standard Features

Internal rechargeable battery with dynamic charge status, removable stainless steel pan, digital external calibration software, selectable environmental settings, fast stabilization, integrated level bubble and adjustable feet, single or dual bright backlit display with selectable Auto-Off, selectable weighing unit, included AC power adapter.

Compliance

• **Food Service:** NSF Listed/Certified to NSF/ANSI 169-2005 Special Purpose Food Equipment and Devices (formerly NSF C-2).

Approvals

- **Electrical/Emissions:** CE listed, meets AS/NZS4251.1 Emission/AS/NZS4252.1 Immunity, FCC Class A Part 15 operation, Industry Canada Class A. UL_{100} AC power pack.
Compliant to Directive 2002/96/EC on waste electrical and electronic equipment (WEEE).
- **Quality:** Ohaus quality management system registered to ISO 9001:2008

OHAUS CORPORATION
* 7 Campus Drive
Suite 310
Parsippany, NJ 07054 USA
Tel: 800.672.7722
973.377.9000
Fax: 973.944.7177
www.ohaus.com

With offices throughout Europe,
Asia, and Latin America

* **ISO 9001**
Registered Quality Management System